

TECHNICAL SPECIFICATIONS

FHS 55

	MODEL	FHS 55 STD	FHS 55 P
	TYPE	Standard	Reach
1	CAPACITY @ 24" LOAD CENTER	5,500 lbs.	5,500 lbs.
2	DIESEL ENGINE	56 hp	56 hp
2a	ENGINE EMISSION COMPLIANCE EPA	TIER 4 Final	TIER 4 Final
3	MAXIMUM ENGINE RPM	2,700 rpm	2,700 rpm
4	ELECTRICAL SYSTEM	12 Volt	12 Volt
5	DRIVE WHEELS (ALL WITH BRAKES)	3	3
6	STEERING	Hydrostatic	Hydrostatic
7	TIRE TYPE FRONT : SKID STEER		
	TIRE TYPE: TRACTOR GRIP	31" x 15.5" - 15" 8 PLY	31" x 15.5" - 15" 8 PLY
8	TIRE OUTSIDE DIAMETER	31"	31"
9	TIRE WIDTH	15 1/2"	15 1/2"
10	MAXIMUM SPEED	7 mph	7 mph
11	MAXIMUM GRADABILITY	30%	30%
12	TURNING RADIUS	75"	81"
13	UNLADEN WEIGHT EXCLUDING FORKS	120" MAST 6,220 lbs. 144" MAST 6,340 lbs.	120" MAST 7,270 lbs. 144" MAST 7,390 lbs.
14	WORKING PRESSURE FOR ATTACHMENTS	3,000 psi	3,000 psi
15	TILT OF MAST (FORWARD / BACK)	10° / 8°	10° / 8°
15a	TILT OF FORK CARRIAGE (FORWARD / BACK)		0° / 6°
16	SIDESHIFT	6"	5"
17	FORK SECTION: PALLET BRICK / BLOCK LUMBER (L x W x H)	48" x 4" x 1 3/4" 48" x 2" x 2" 48" x 6" x 2"	48" x 4" x 2" 48" x 2" x 2" 48" x 6" x 2"
18	MAST CARRIAGE TRAVEL	31.5"	37.4"
18a	REACH ACROSS TRUCK BED		51"
19	COUNTERWEIGHTS	No	No
A	HEIGHT TO TOP OF CANOPY	101"	101"
B	FORK CARRIAGE WIDTH	47 1/4" (CLASS IV 25" OPENING)	47 1/4" (CLASS IV 25" OPENING)
C	FRAME OPENING	58"	58"
D	OVERALL WIDTH	101 1/2"	101 1/2"
E	OVERHANG	60"	66"
F	WHEEL BASE	65 1/2"	71 1/2"
G	C. OF G. FROM FORK FACE	18 3/4"	20 1/2"
H1	LIFT HEIGHT	120" 144"	120" 144"
H2	MAST HEIGHT COLLAPSED	88 3/4" 100 3/4"	88 3/4" 100 3/4"
H3	MAST HEIGHT RAISED	148 3/4" 172 3/4"	201" 225"
J	GROUND CLEARANCE	11"	11"
K	FACE OF FORK TO CENTER OF FRONT TIRE	15"	15"
L	ANSI STANDARD	B56.14	B56.14

FHS 55 4W

FHS 55 4WP

4 Way	4 Way Reach
5,500 lbs.	5,500 lbs.
56 hp	56 hp
TIER 4 Final	TIER 4 Final
2,700 rpm	2,700 rpm
12 Volt	12 Volt
3	3
Hydrostatic	Hydrostatic
31" x 13" - 16.5" 10 PLY	31" x 13" - 16.5" 10 PLY
31" x 15.5" - 15" 8 PLY	31" x 15.5" - 15" 8 PLY
31"/31"	31"/31"
13"/15 1/2"	13"/15 1/2"
7 mph	7 mph
30% (15%)	30% (15%)
75"	81"
120" MAST 6,925 lbs. 144" MAST 7,045 lbs.	120" MAST 7,985 lbs. 144" MAST 8,105 lbs.
3,000 psi	3,000 psi
10°/8°	10°/8°
	0°/6°
6"	5"
48" x 6" x 2"	48" x 6" x 2"
31.5"	37.4"
	51"
No	No
101"	101"
47 1/4" (CLASS IV 25" OPENING)	47 1/4" (CLASS IV 25" OPENING)
58"	58"
101 1/2" 101"	101 1/2" 101"
60"	66"
65 1/2"	71 1/2"
17"	17 3/4"
120" 144"	120" 144"
88 3/4" 100 3/4"	88 3/4" 100 3/4"
148 3/4" 172 3/4"	201" 225"
11"	11"
15"	15"
B56.14	B56.14

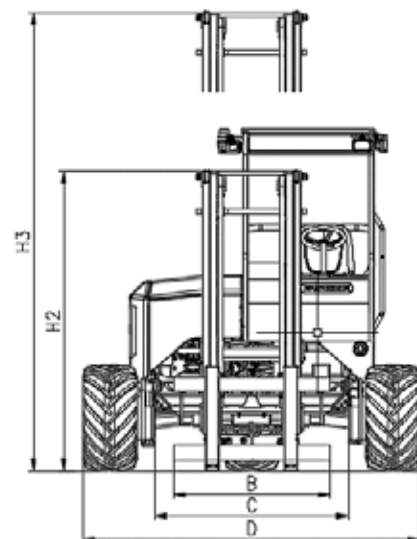
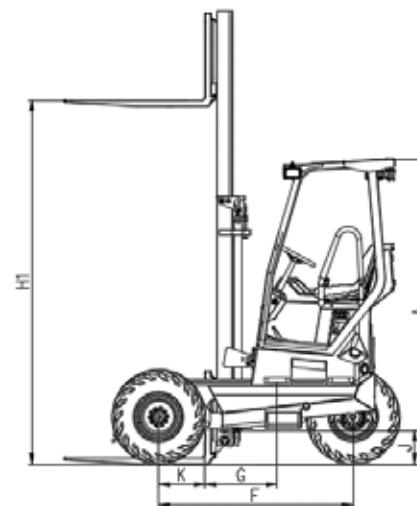

Weights will change depending on wheel and fork options.
Weights listed do not include forks or accessories.